

规格书编号

SPEC NO :

产品规格书

SPECIFICATION

CUSTOMER 客户: _____
PRODUCT 产品: SAW FILTER
MODEL NO 型号: HDBF65A1D SIP5D
PREPARED 编制: _____ CHECKED 审核: _____
APPROVED 批准: _____ DATE 日期: 2009-5-15

客户确认 CUSTOMER RECEIVED:		
审核 CHECKED	批准 APPROVED	日期 DATE

无锡市好达电子有限公司
Shoulder Electronics Limited

1.SCOPE

SHOULDER's SAW filter series have broad line up products meeting all broadcast standard including NTSC,PAL and SECAM systems. These filters are composed of two interdigital transducers on a single-crystal, piezoelectrical chip. they are used in electronic equipments such as TV and so on.

2.Construction

2.1 Dimension and materials

Manufacturer's name : SHOULDER ELECTRONICS Co. LTD(CHINA)

Type : BF65A1D

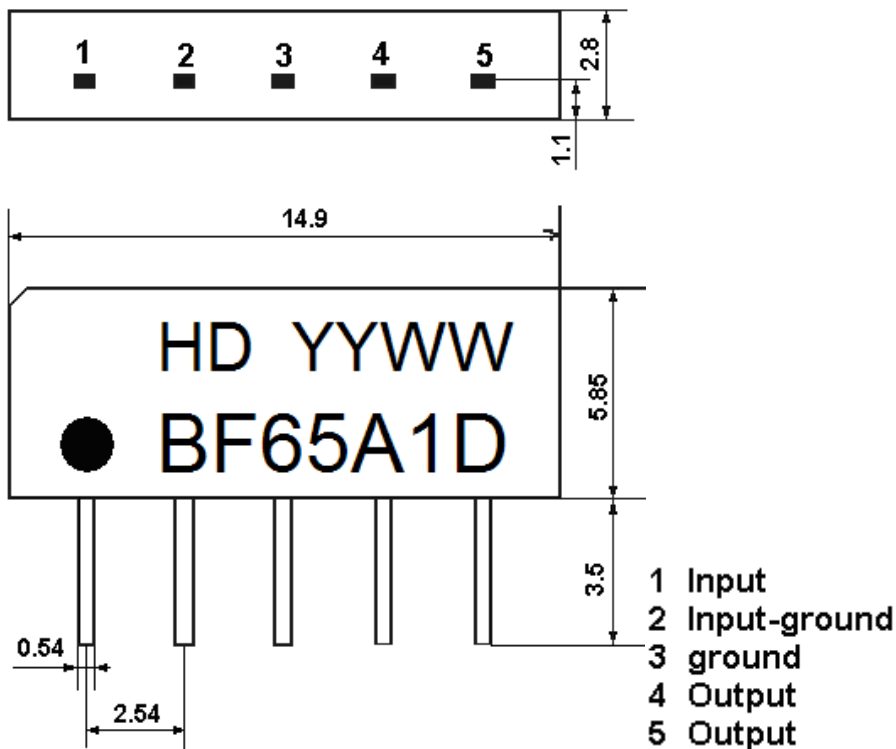

YY:year
WW:week

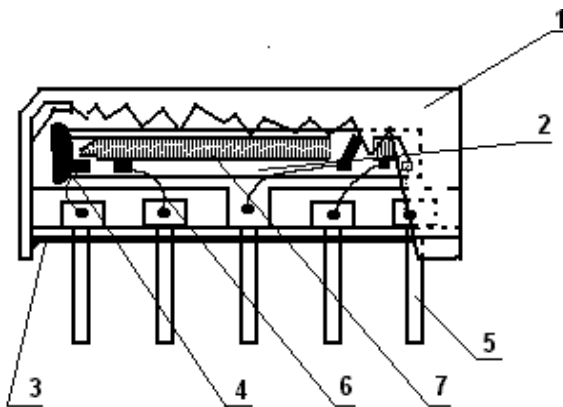

Components	Materials
1.Outer casing	PPS
2.Substrate	Lithium niobate
3.Base	Epoxy resin
4.Absorber	Epoxy resin
5.Lead	Cu alloy+Au plate
6.Bonding wire	AlSi alloy
7.Electrode	Al

2.2. Circuit construction, measurement circuit

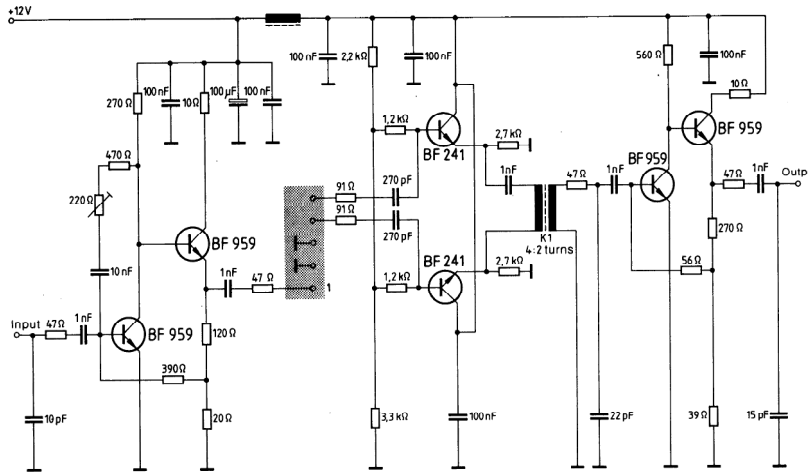

Test circuit for SIP-5 filter
Input impedance of the symmetrical post-amplifier: 2 kΩ in parallel with 3 pF

3.Characteristics

Items	Conditions	Specifications
Standard atmospheric conditions	Unless otherwise specified , the standard rang of atmospheric conditions for making measurements and tests is as follows; Ambient temperature : 15°C to 35°C Relative humidity : 25% to 85% Air pressure : 86kPa to 106kPa	There shall be no damage.
Operating temperature rang	Operating temperature rang is the rang of ambient temperatures in which the filter can be operated continuously. -10°C ~ +60°C	
Storage temperature rang	Storage temperature rang is the rang of ambient temperatures at which the filter can be stored without damage. Conditions are as specified elsewhere in these specifications. -40°C ~ +70°C	
Reference temperature	+25°C	

3.1 Maximum Rating

DC voltage	VDC	12	V	Between any terminals
AC voltage	Vpp	10	V	Between any terminals

3.2 Electrical Characteristics

Source impedance

 $Z_S=200\ \Omega$

Load impedance

 $Z_L=200\ \Omega$
 $T_A=25^\circ\text{C}$

Item	Freq	min	typ	max	
Center frequency center between 20dB point	Fo	65.68	65.75	65.92	MHz
Insertion attenuation Reference level at peak		-	20.0	24.0	dB
Pass bandwidth	B3dB	-	0.52		MHz
	B20dB	-	1.3	1.5	MHz
Sidelobe	55.00 ~ 63.50MHz	40.0	45.0	-	dB
	63.50 ~ 64.50MHz	32.0	39.0	-	dB
	67.00 ~ 68.50MHz	31.0	38.0	-	dB
	68.50 ~ 75.00MHz	36.0	44.0	-	dB
Temperature coefficient			-18		ppm/k

3.3 Environmental Performance Characteristics

Item	Condition	Specifications			
High temperature	The specimen shall be store at a temperature of $80\pm 2^\circ\text{C}$ for $96\pm 4\text{h}$. Then it shall be subjected to standard atmospheric conditions for 1h, after which measurement shall be made within 1h.	Mechanical characteristics and specifications in electrical characteristics shall be satisfied. There shall be no excessive change in appearance.			
Low temperature	The specimen shall be store at a temperature of $-20\pm 3^\circ\text{C}$ for $96\pm 4\text{h}$. Then it shall be subjected to standard atmospheric conditions for 1h, after which measurement shall be made within 1h.				
Humidity	The specimen shall be store at a temperature of $40\pm 2^\circ\text{C}$ with relative humidity of 90% to 96% for $96\pm 4\text{h}$. Then it shall be subjected to standard atmospheric conditions for 1h, after which measurement shall be made within 1h.				
Thermal shock	The specimen shall be subjected to 8 continuous cycles each as shown below. Then it shall be subjected to standard atmospheric conditions for 1h, after which measurement shall be made within 1h.				
	<table border="1"> <tr> <td></td> <td>Temperature</td> <td>Duration</td> </tr> </table>		Temperature	Duration	
	Temperature	Duration			

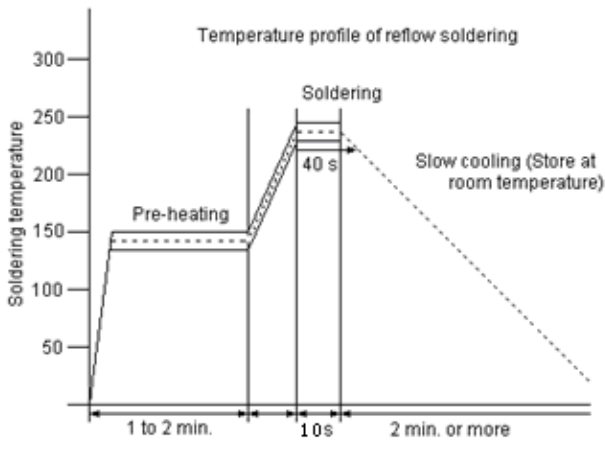
	<table border="1"> <tr> <td>1</td> <td>+25 °C=>-40 °C</td> <td>0.5h</td> </tr> <tr> <td>2</td> <td>-40 °C</td> <td>4h</td> </tr> <tr> <td>3</td> <td>-40 °C=>+85 °C</td> <td>2h</td> </tr> <tr> <td>4</td> <td>+85 °C</td> <td>4h</td> </tr> <tr> <td>5</td> <td>+85 °C=>+25 °C</td> <td>0.5h</td> </tr> <tr> <td>6</td> <td>+25 °C</td> <td>1h</td> </tr> </table>	1	+25 °C=>-40 °C	0.5h	2	-40 °C	4h	3	-40 °C=>+85 °C	2h	4	+85 °C	4h	5	+85 °C=>+25 °C	0.5h	6	+25 °C	1h	
1	+25 °C=>-40 °C	0.5h																		
2	-40 °C	4h																		
3	-40 °C=>+85 °C	2h																		
4	+85 °C	4h																		
5	+85 °C=>+25 °C	0.5h																		
6	+25 °C	1h																		
Resistance to Soldering heat	<p>Reflow soldering method Peak: 255 ±5 °C, 220 ±5 °C, 40s At electrode temperature of the specimen.</p>  <p>The specimen shall be passed through the reflow furnace with the condition shown in the above profile for 1 time. The specimen shall be stored at standard atmospheric conditions for 1h, after which the measurement shall be made. Test board shall be 1.6 mm thick. Base material shall be glass fabric base epoxy resin.</p>																			
Solder ability	Immerse the pins melt solder at 260°C+5/-0°C for 5 sec.	More then 95% of total area of the pins should be covered with solder																		

3.4 Mechanical Test

Items	Conditions	Specifications
Vibration	600-3300rpm amplitude 1.5mm 3 directions 2 H each	There shall be no damage.
Drop	On maple plate from 1 m high 3 times	
Lead pull	Pull with 1 kg force for 30 seconds	
Lead bend	90° bending with 500g weigh 2 times	

3.5 Voltage Discharge Test

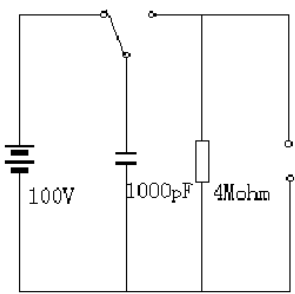
Item	Condition	Specifications
Surge	Between any two electrode 	There shall be no damage

3.6 Frequency response:

►1: Transmission /M Log Mag 10.0 dB/ Ref -57.25 dB

►2: Transmission /M Log Mag 1.0 dB/ Ref -19.79 dB

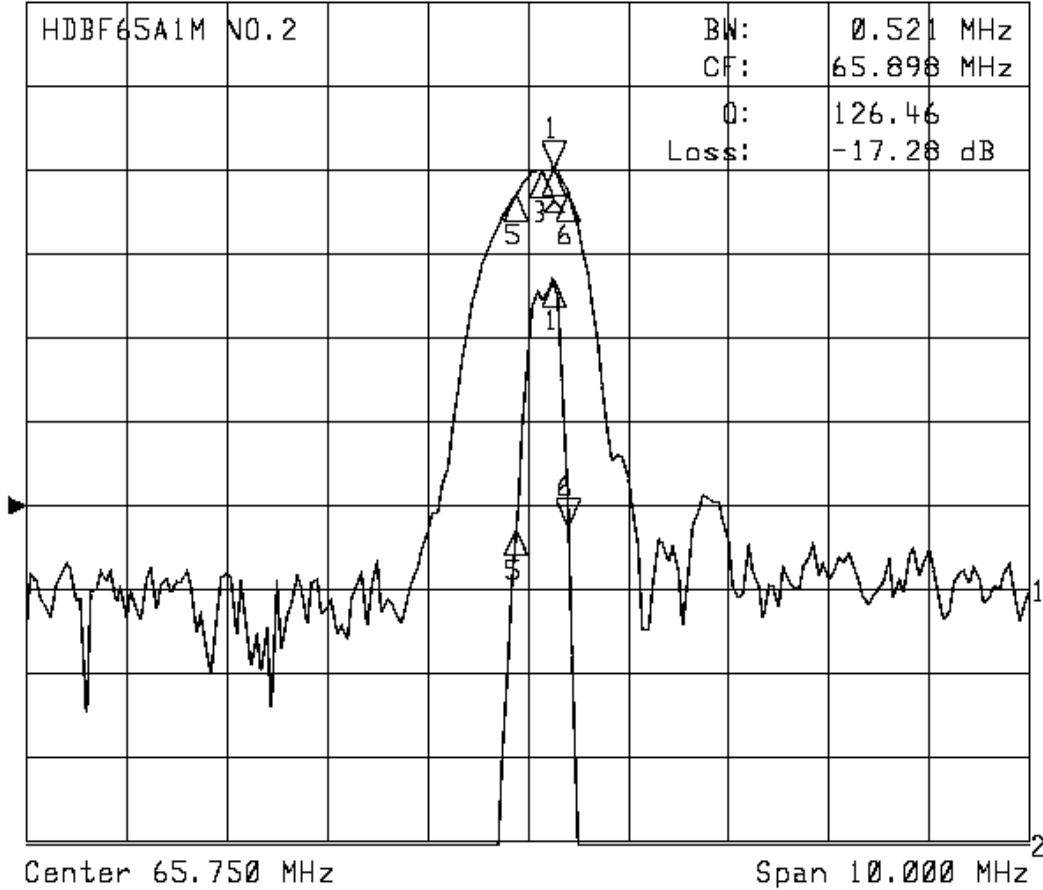

1: Mkr Δ(MHz)	dB	2: Mkr (MHz)	dB
1> 0.0000	0.000	1: 66.0000	-17.079
3: -0.1017	-0.235		
5: -0.3637	-2.990	5: 65.6363	-20.062
6: 0.1597	-2.959	6> 66.1597	-20.039